

TYPE 55 MSP 21-1/4" 2000 ANNULAR BLOWOUT PREVENTER

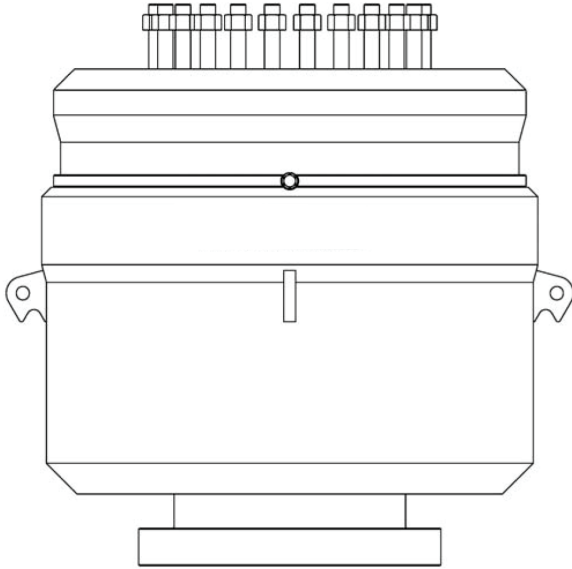

The Type 55 (MSP) Annular Blowout Preventer is designed for safe well pressure control during surface casing drilling operations. The simple design has been proven and accepted for reliable operation in all oil and gas areas in the world. Four main components: body, piston, head, and packing element allow for easy maintenance and reliability. The packing element can close on all pipe, casing, wireline, coiled tubing, and other objects to its full working pressure. Stripping of pipe, tubing, and wireline through the packing element can also be accomplished at lower pressures. The 55 Blowout Preventer can also perform open hole closure per the requirements of ISO 13533 (16A).

The normal configuration of the 55 Blowout Preventer is of a flanged bottom connection and a studded top flange connection. Hydraulic operation is performed by connection to an open and close (NPT) port located on the body, which is connected to the control system. Closing of the BOP is

made by upward movement of the Piston. A tapered, steel reinforced rubber-packing element is forced inward by an upward movement of the piston. Opening of the BOP is made by the hydraulic movement of the piston downward, which allows expansion of the Packing Element to its original open position in the BOP. Steel inserts prevent extrusion of the rubber and feed inward to close on any pipe or tubular in the well bore. The steel inserts move radially inward during operation.

Replacement of the packing element is performed by unscrewing the Head, lifting the Head from the Body, and lifting of the element out of the piston bowl. A new element is then lowered into the piston bowl. An optional latch head design is available for fast, efficient removal of the head from the body.

All materials used in the construction of the Type 55 Annular Blowout Preventer are rated by NACE MR-0175 and ISO 13533 for use in hydrogen sulfide environments.

SPECIAL FEATURES OF THE TYPE 55 (MSP) ANNULAR BLOWOUT PREVENTER:

- Designed and manufactured to ISO 13533 and API Specification 16A for Drill Through Equipment
- Special rubber materials available for non standard environments
- A screw head or optional latch head design available
- 2000 psi (13.79 Mpa) maximum working pressure
- Standard operation pressure of 1500 psi (10,34 Mpa)
- Available with either 20-3/4" 3000 or 21-1/4" 2000 flanged bottom connections
- All hydraulic operating ports are 1" NPT
- Forged materials rated for H2S service